

1 PLAN VIEW @ GNOME HOUSE
SCALE 3/8" = 1'-0"

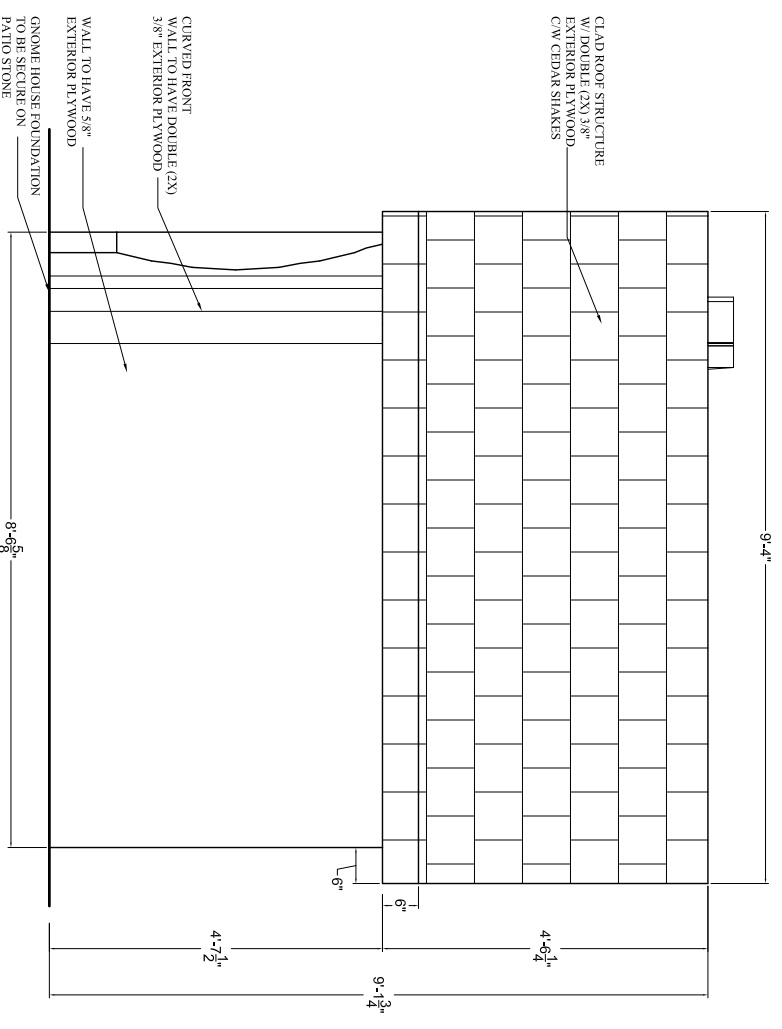

A ELEVATION @ GNOME HOUSE
SCALE 3/8" = 1'-0"

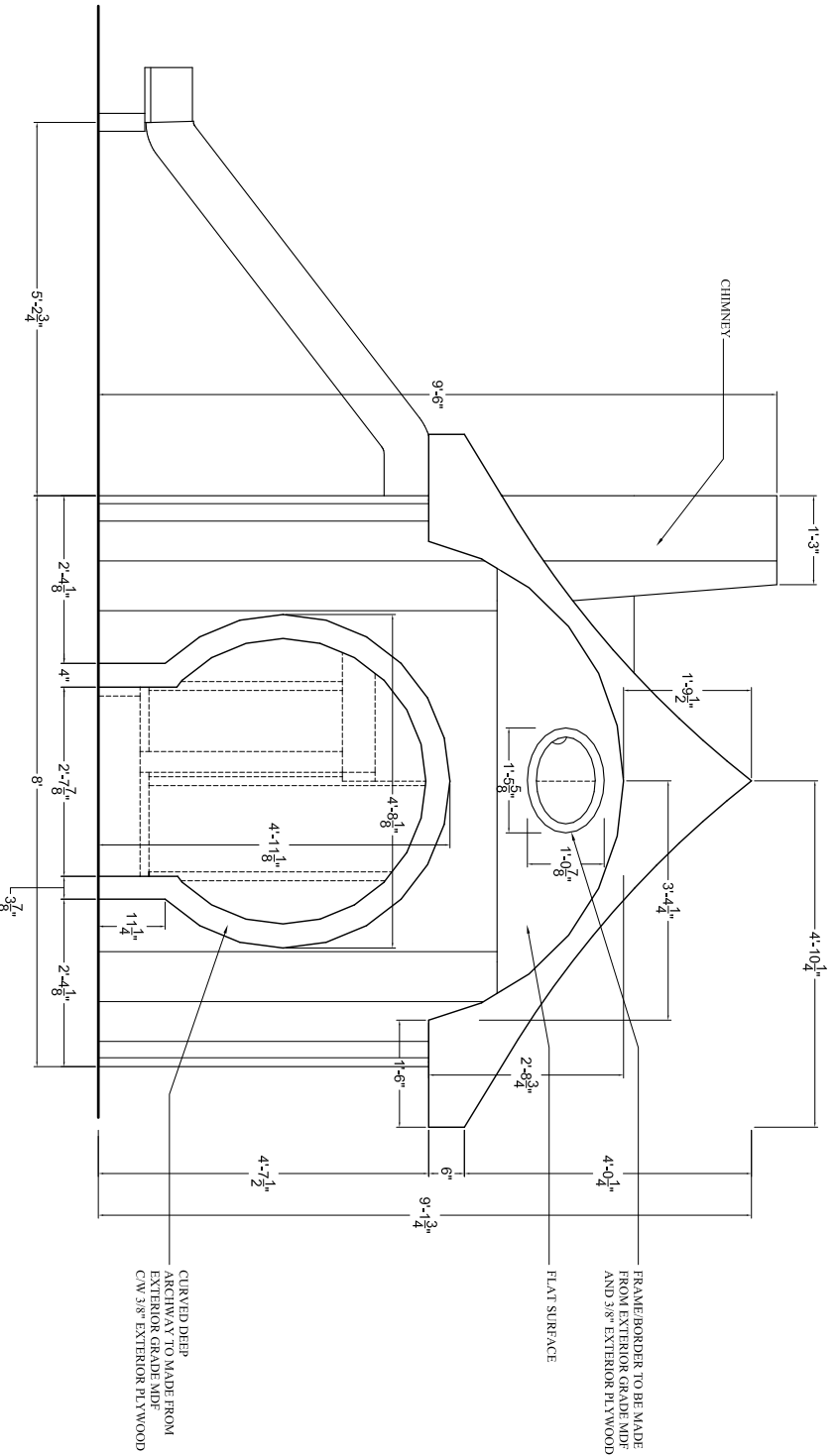

B ELEVATION @ GNOME HOUSE
SCALE 3/8" = 1'-0"

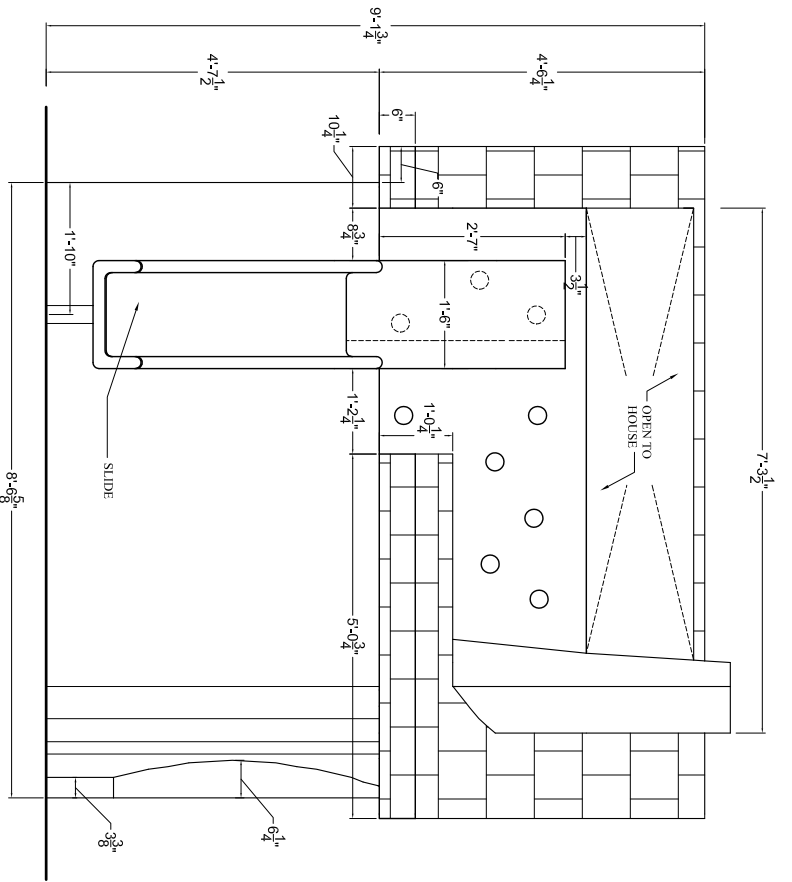

C ELEVATION @ GNOME HOUSE
SCALE 3/8" = 1'-0"



REVISION	DATE	DESCRIPTION
1	JULY XX, 13	ISSUED TO CONTRACTOR

CONTRACTORS MUST CHECK AND VERIFY ALL DIMENSION ON THE JOB AND REPORT ANY DISCREPANCY TO THE PROJECT MANAGER BEFORE PROCEEDING WITH THE WORK.

DESIGNER TO BE NOTIFIED OF ANY DISCREPANCIES AND ERRORS.

DO NOT SCALE DRAWING

DATE:	JULY 09, 13.
PREPARED BY:	JK
SCALE:	3/8" = 1'-0"
TITLE:	PLAN & ELEVATIONS @ GNOME HOUSE

DRAWING #	F-7
-----------	-----

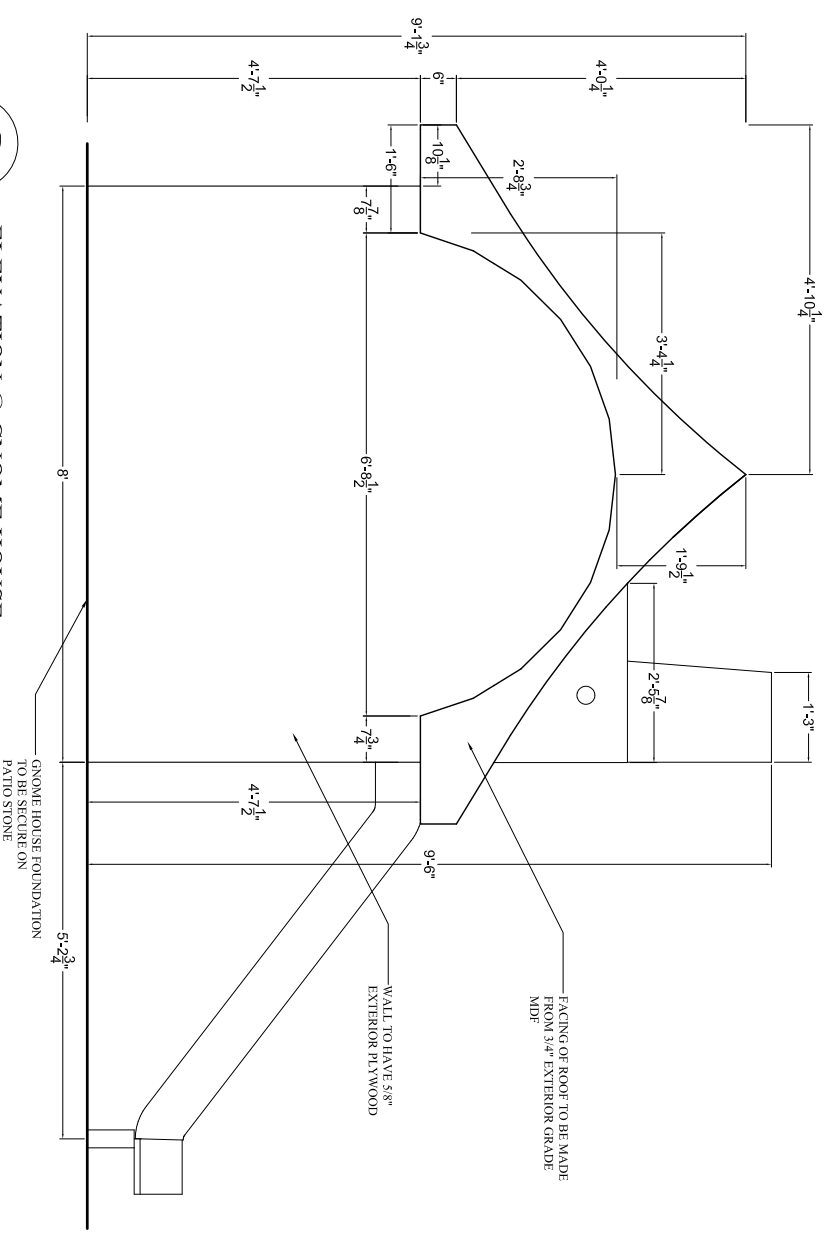

D
ELEVATION @ GNOME HOUSE
SCALE 3/8" = 1'-0"

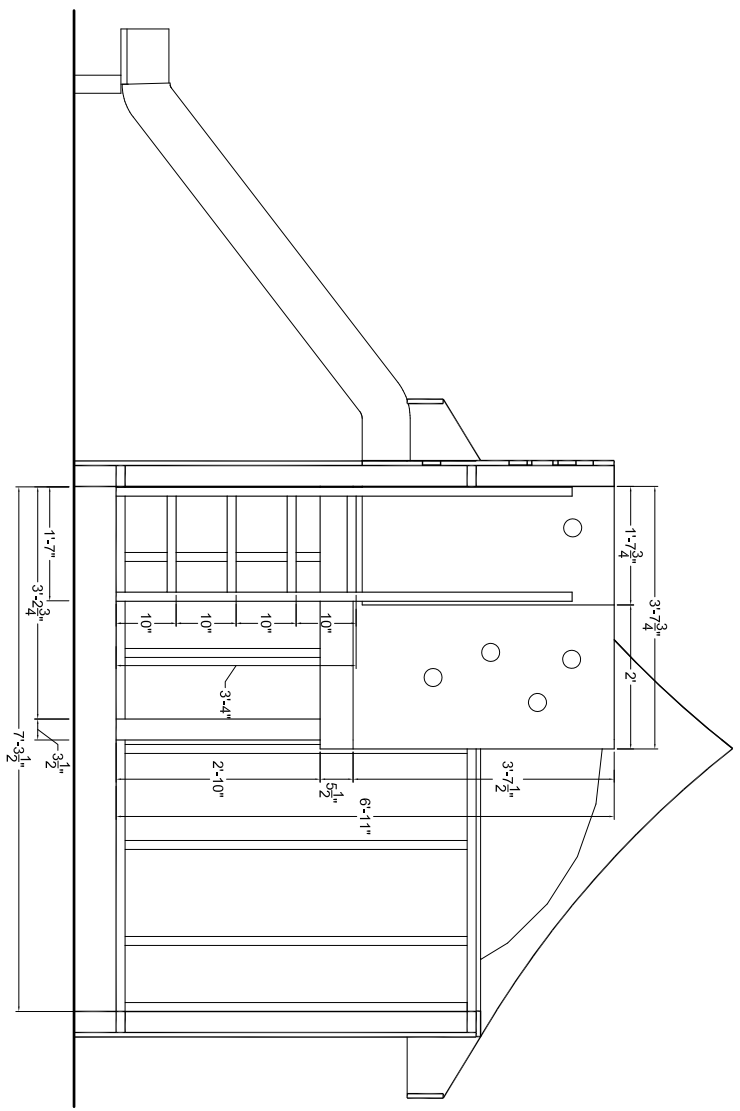

1
ELEVATION @ GNOME HOUSE
SCALE 3/8" = 1'-0"

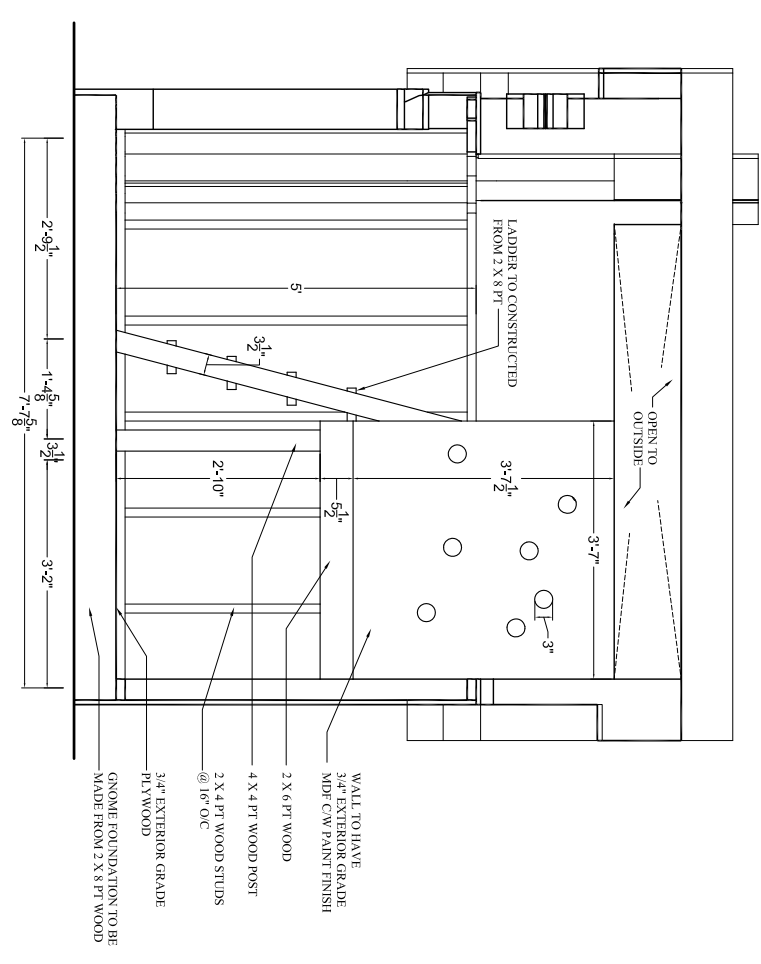

2
ELEVATION @ GNOME HOUSE
SCALE 3/8" = 1'-0"

DRAWING #

F-8

DATE:	JULY 09.13.
PREPARED BY:	JK
SCALE:	3/8" = 1'-0"
TITLE:	ELEVATION & DETAILS @ GNOME HOUSE

CONTRACTORS MUST CHECK AND VERIFY ALL DIMENSION ON THE JOB AND REPORT ANY DISCREPANCY TO THE PROJECT MANAGER BEFORE PROCEEDING WITH THE WORK.

DESIGNER TO BE NOTIFIED OF ANY DISCREPANCIES AND ERRORS.

DO NOT SCALE DRAWING

REVISION	DATE	DESCRIPTION
1	JULY XX.13	ISSUED TO CONTRACTOR



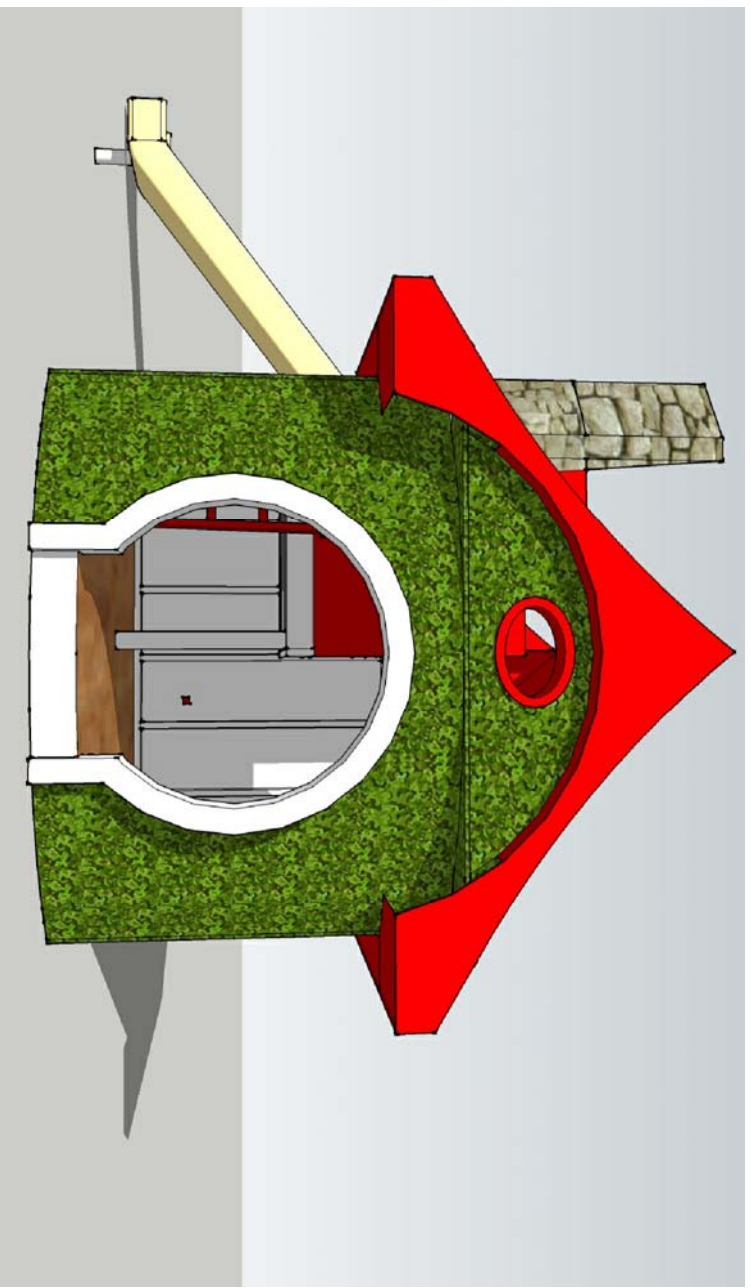

1 PERSPECTIVE @ GNOME HOUSE
NOT TO SCALE

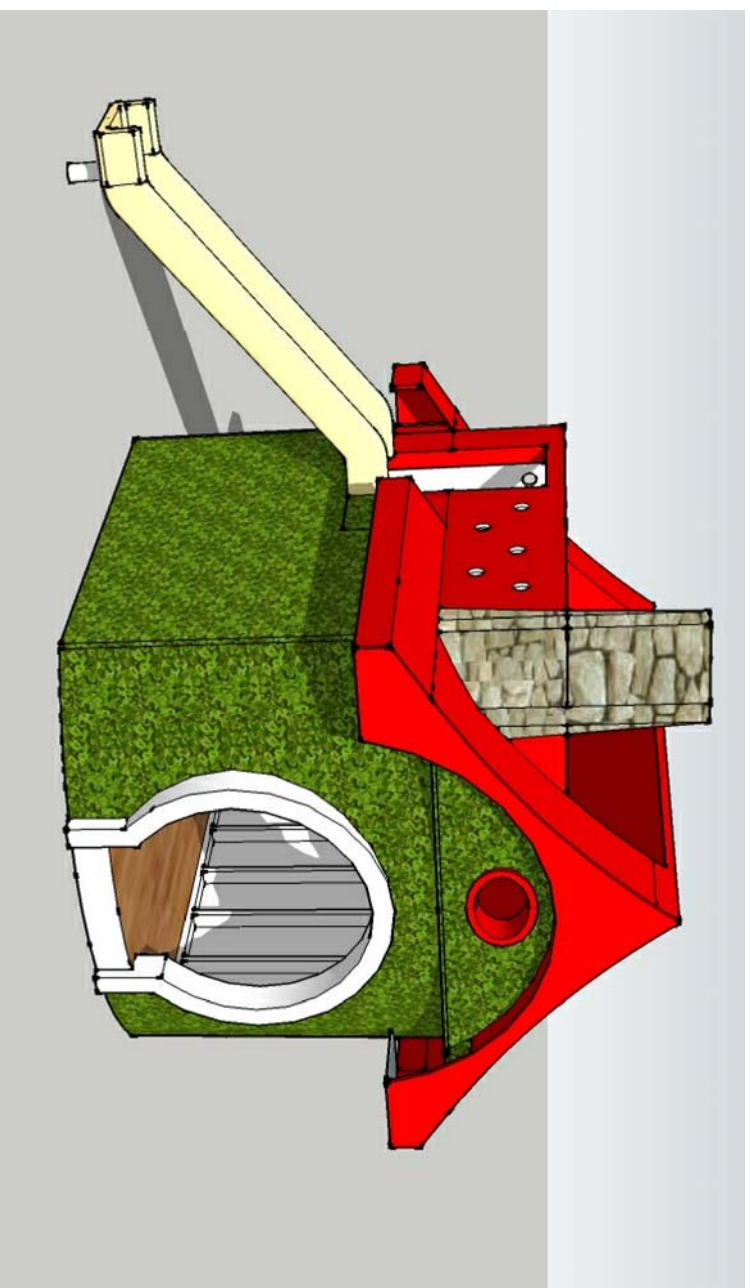

2 PERSPECTIVE @ GNOME HOUSE
NOT TO SCALE

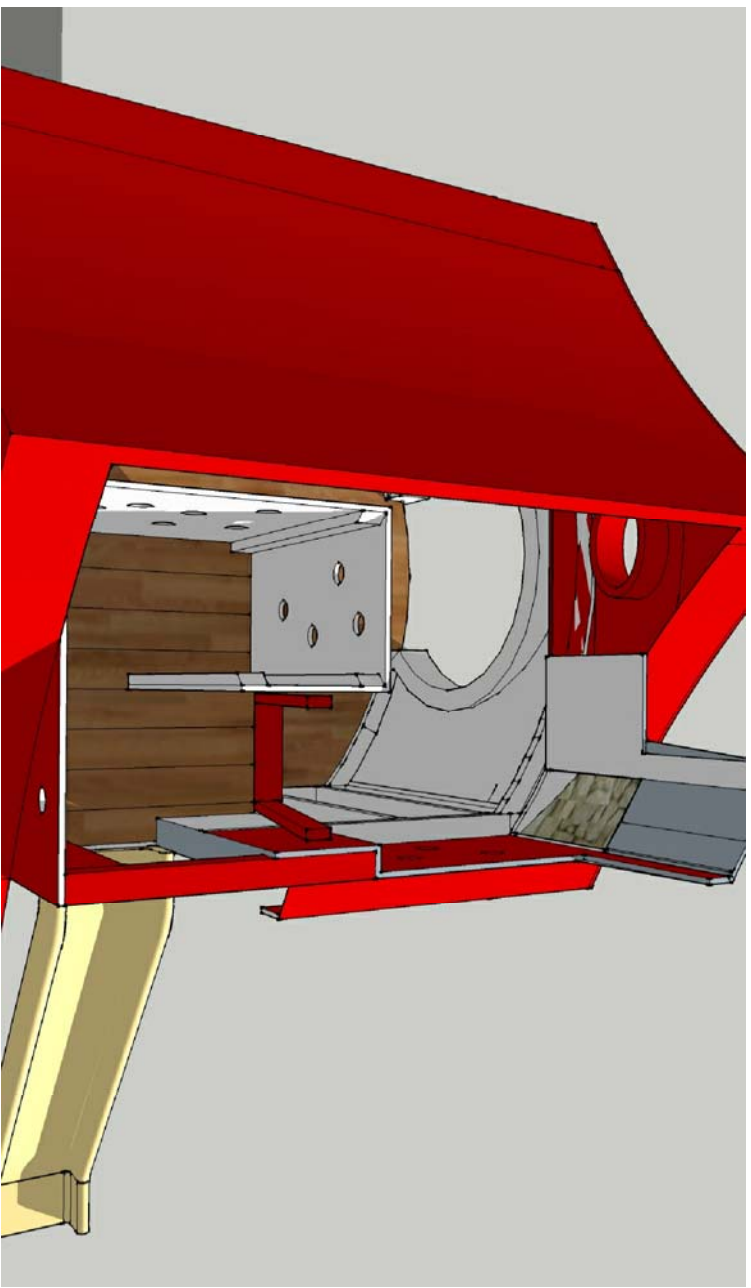

3 PERSPECTIVE @ GNOME HOUSE
NOT TO SCALE

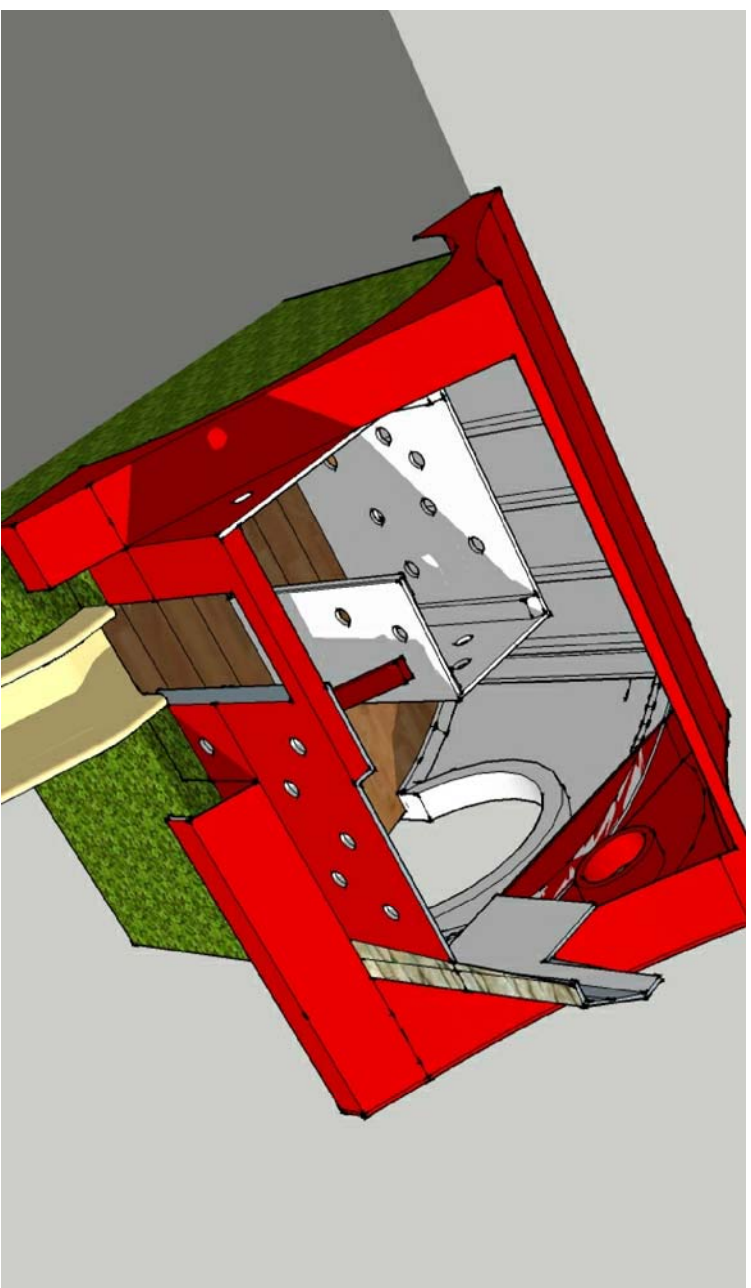

4 PERSPECTIVE @ GNOME HOUSE
NOT TO SCALE

	<table border="1"> <thead> <tr> <th colspan="2">REVISION DATE</th> </tr> </thead> <tbody> <tr> <td>1</td> <td>ISSUED TO CONTRACTOR JULY XX-13</td> </tr> <tr> <td> </td> <td> </td> </tr> <tr> <td> </td> <td> </td> </tr> <tr> <td> </td> <td> </td> </tr> <tr> <td> </td> <td> </td> </tr> </tbody> </table>		REVISION DATE		1	ISSUED TO CONTRACTOR JULY XX-13									<p>CONTRACTORS MUST CHECK AND VERIFY ALL DIMENSION ON THE JOB AND REPORT ANY DISCREPANCY TO THE PROJECT MANAGER BEFORE PROCEEDING WITH THE WORK.</p> <p>DESIGNER TO BE NOTIFIED OF ANY DISCREPANCIES AND ERRORS.</p> <p>DO NOT SCALE DRAWING</p>	<table border="1"> <tr> <td>DATE:</td> <td>JULY 09.13.</td> <td>DRAWING #</td> <td rowspan="4" style="font-size: 2em; text-align: center;">F-9</td> </tr> <tr> <td>PREPARED BY:</td> <td>JK</td> <td> </td> </tr> <tr> <td>SCALE:</td> <td>N.T.S.</td> <td> </td> </tr> <tr> <td>TITLE:</td> <td>PERSPECTIVES @ GNOME HOUSE</td> <td> </td> </tr> </table>	DATE:	JULY 09.13.	DRAWING #	F-9	PREPARED BY:	JK		SCALE:	N.T.S.		TITLE:	PERSPECTIVES @ GNOME HOUSE	
	REVISION DATE																												
1	ISSUED TO CONTRACTOR JULY XX-13																												
DATE:	JULY 09.13.	DRAWING #	F-9																										
PREPARED BY:	JK																												
SCALE:	N.T.S.																												
TITLE:	PERSPECTIVES @ GNOME HOUSE																												